



US007443302B2

(12) **United States Patent**
Reeder et al.

(10) **Patent No.:** **US 7,443,302 B2**
(45) **Date of Patent:** ***Oct. 28, 2008**

(54) **CAREGIVER AND EQUIPMENT
MONITORING AND CONTROL SYSTEM**

(75) Inventors: **Ryan Anthony Reeder**, Brookville, IN (US); **Kenneth L. Kramer**, St. Paul, IN (US); **William L. Jacques, II**, Batesville, IN (US); **Carl W. Riley**, Milan, IN (US); **Richard J. Schuman**, Cary, NC (US)

(73) Assignee: **Hill-Rom Services, Inc.**, Wilmington, DE (US)

(*) Notice: Subject to any disclaimer, the term of this patent is extended or adjusted under 35 U.S.C. 154(b) by 352 days.

This patent is subject to a terminal disclaimer.

(21) Appl. No.: **11/075,979**

(22) Filed: **Mar. 9, 2005**

(65) **Prior Publication Data**

US 2005/0168341 A1 Aug. 4, 2005

Related U.S. Application Data

(63) Continuation of application No. 09/849,688, filed on May 4, 2001, now Pat. No. 6,876,303.

(60) Provisional application No. 60/202,283, filed on May 5, 2000, provisional application No. 60/202,284, filed on May 5, 2000, provisional application No. 60/229,136, filed on Aug. 30, 2000.

(51) **Int. Cl.**
G08B 23/00 (2006.01)

(52) **U.S. Cl.** **340/573.1; 340/286.07; 340/539.12; 340/539.13; 340/825.49; 340/825.52; 340/825.69; 128/903; 128/904; 600/300; 600/301**

(58) **Field of Classification Search** 340/573.1, 340/573.4, 286.06, 286.07, 506, 539.12, 340/539.13, 686.1, 825.19, 825.49, 825.5, 340/825.69, 539.1, 825.52, 825.72; 128/903, 128/904; 600/300, 301
See application file for complete search history.

(56) **References Cited**

U.S. PATENT DOCUMENTS

4,850,040	A	7/1989	Teich et al.
5,036,852	A	8/1991	Leishman
5,291,399	A	3/1994	Chaco
5,417,222	A	5/1995	Dempsey et al.
5,515,426	A	5/1996	Yacenda et al.
5,561,412	A	10/1996	Novak et al.
5,579,775	A	12/1996	Dempsey et al.
5,594,786	A	1/1997	Chaco et al.
5,689,229	A	11/1997	Chaco et al.
5,699,038	A	12/1997	Ulrich et al.
5,738,102	A	4/1998	Lemelson
5,772,599	A	6/1998	Nevo et al.
5,822,418	A	10/1998	Yacenda et al.
5,822,544	A	10/1998	Chaco et al.
5,838,223	A	11/1998	Gallant et al.
5,867,821	A	2/1999	Ballantyne et al.
6,009,333	A	12/1999	Chaco
6,028,519	A *	2/2000	Dessureau et al. 340/573.1

(Continued)

Primary Examiner—Hung T. Nguyen

(74) *Attorney, Agent, or Firm*—Barnes & Thornburg LLP

(57) **ABSTRACT**

A hospital monitoring system for monitoring hospital personnel, a plurality of patient locations for patients, and associated devices is configured to control the associated devices based on the presence of hospital personnel or alarms.

41 Claims, 15 Drawing Sheets

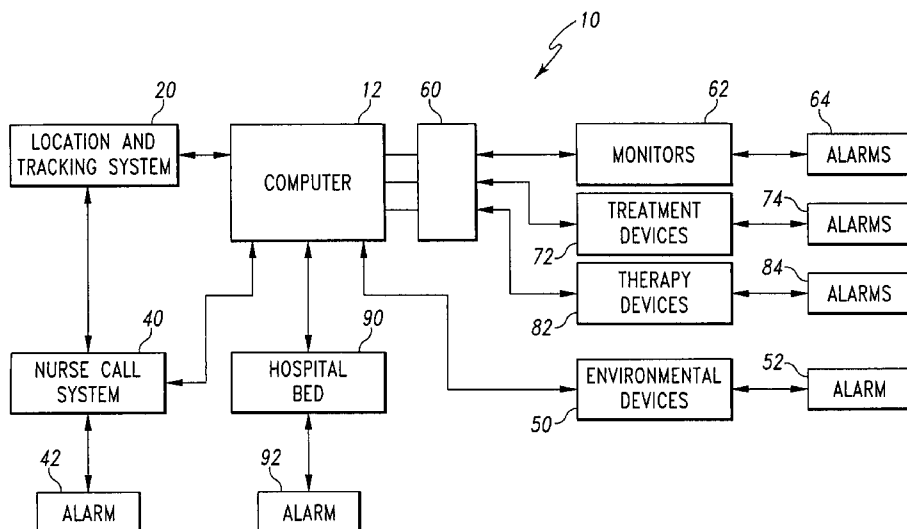

US 7,443,302 B2

Page 2

U.S. PATENT DOCUMENTS

6,078,261	A	6/2000	Davsko	6,147,592	A	11/2000	Ulrich et al.	
6,125,350	A	9/2000	Dirbas	6,259,355	B1 *	7/2001	Chaco et al. 340/286.07
6,135,949	A	10/2000	Russo et al.					

* cited by examiner

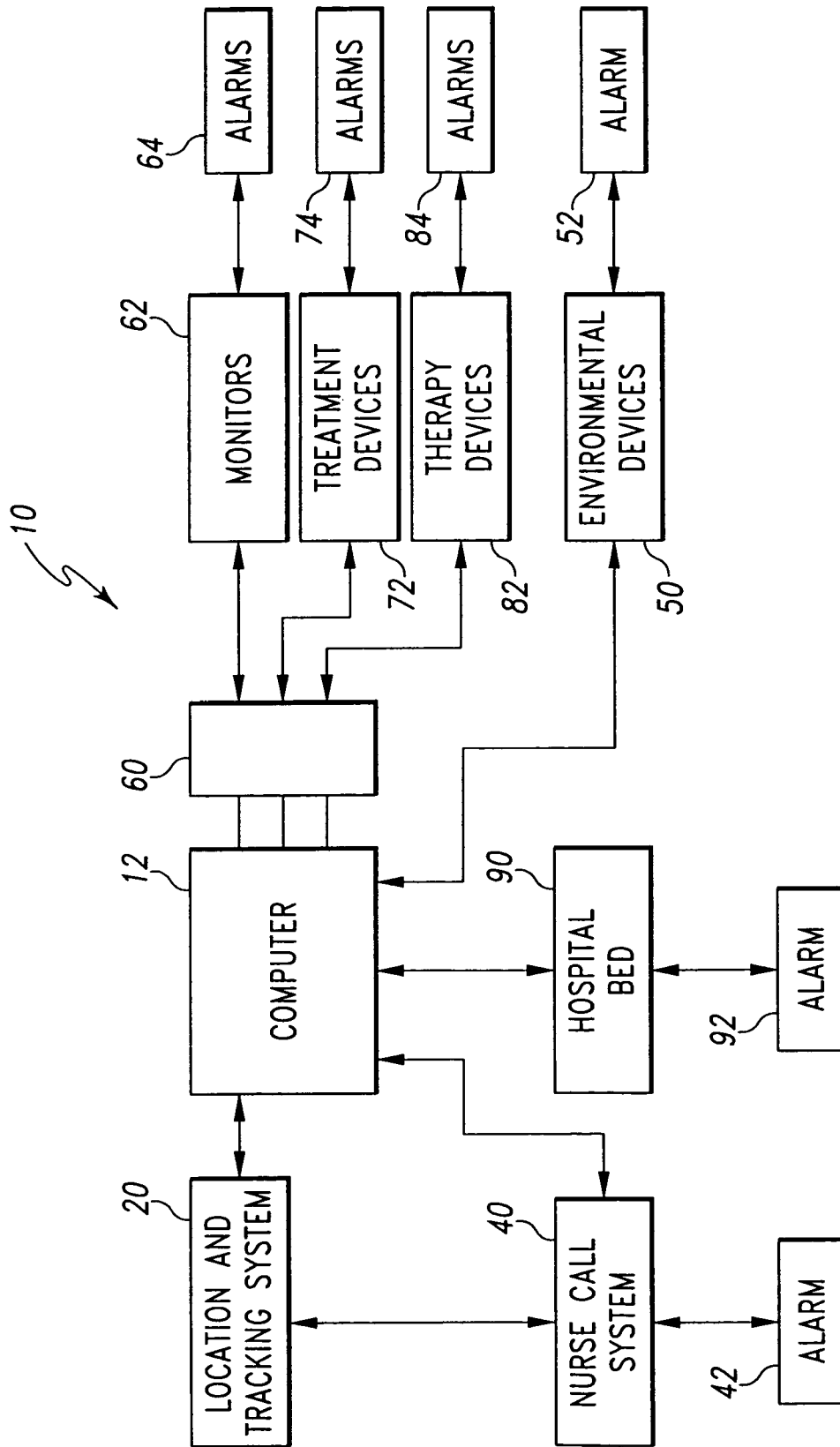

Fig. 1

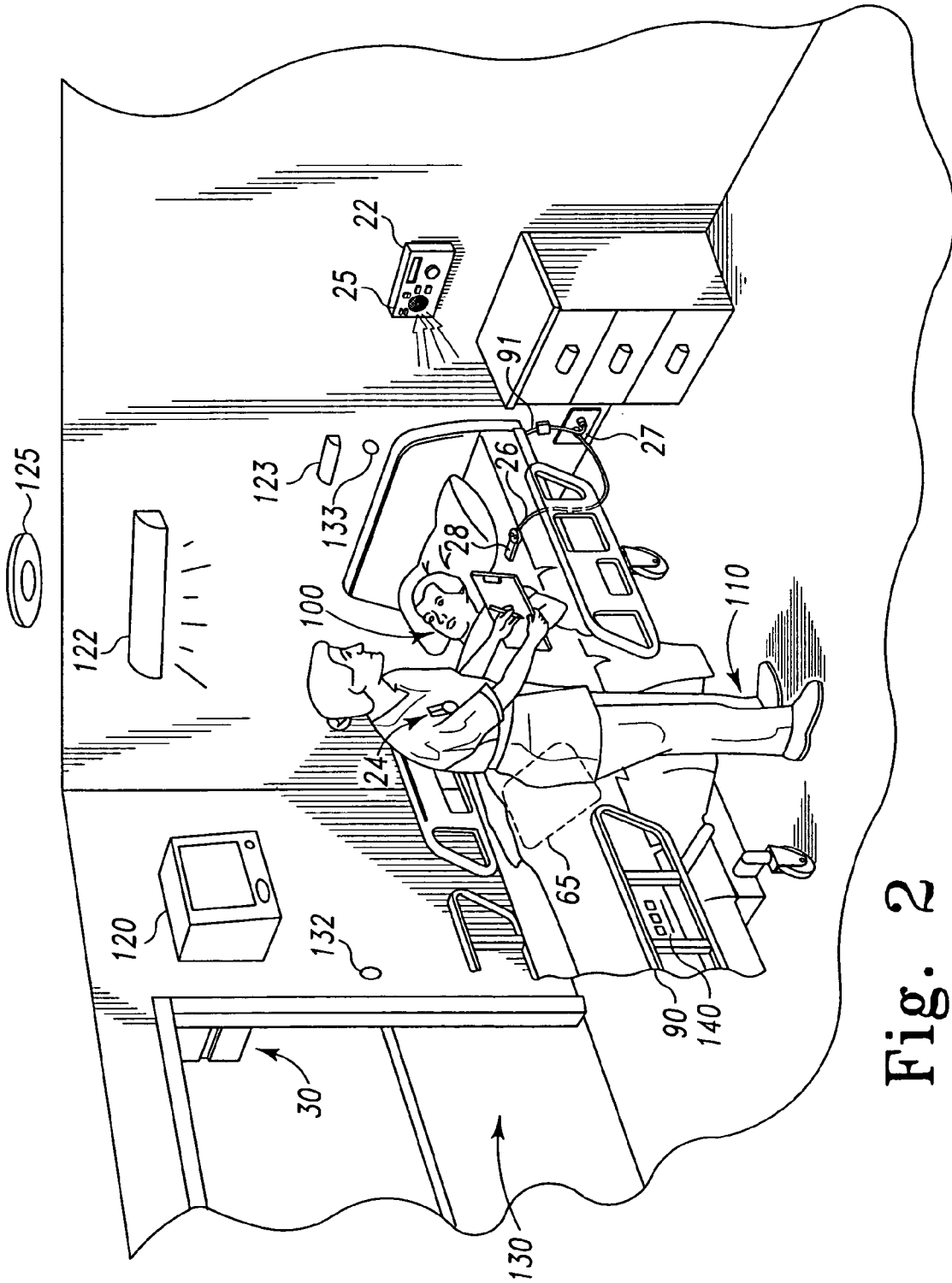

Fig. 2

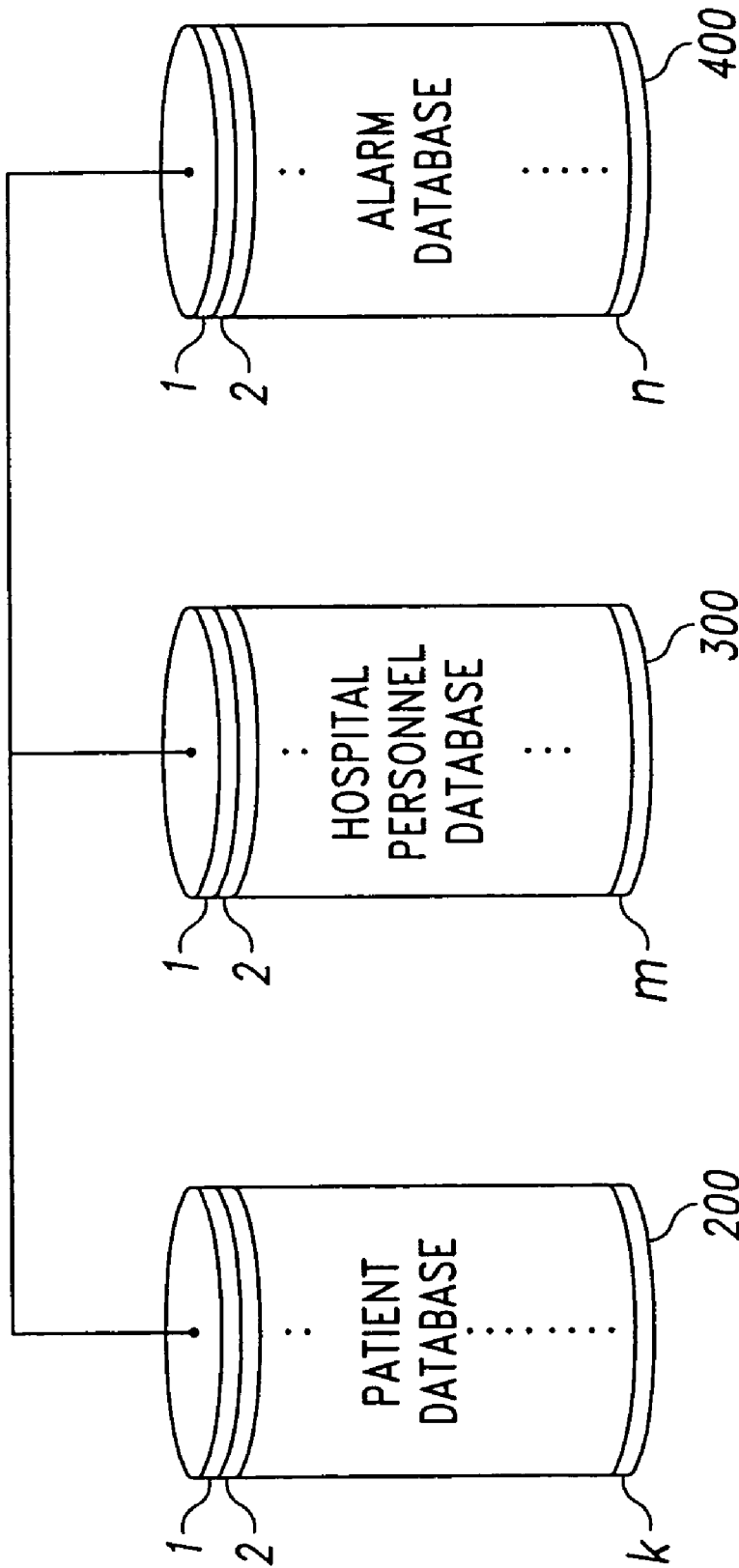

Fig. 3

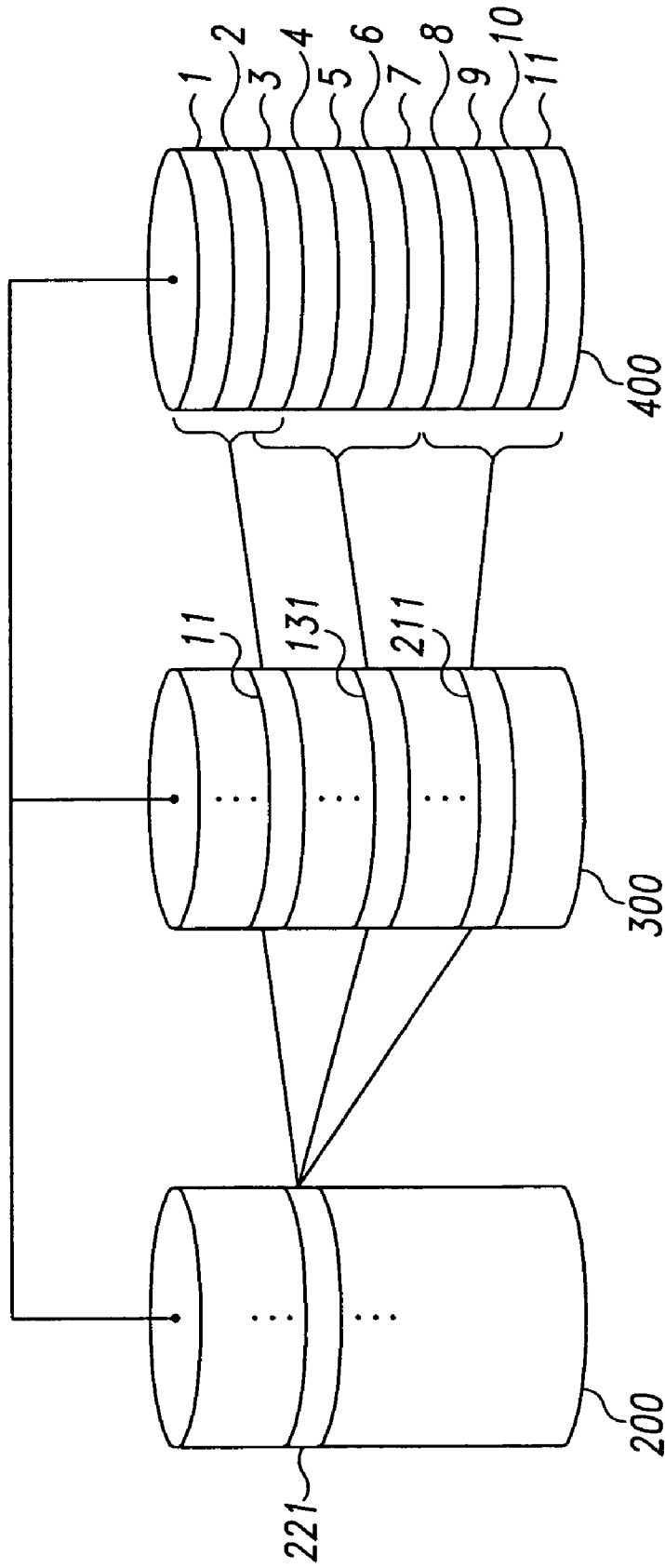

Fig. 4

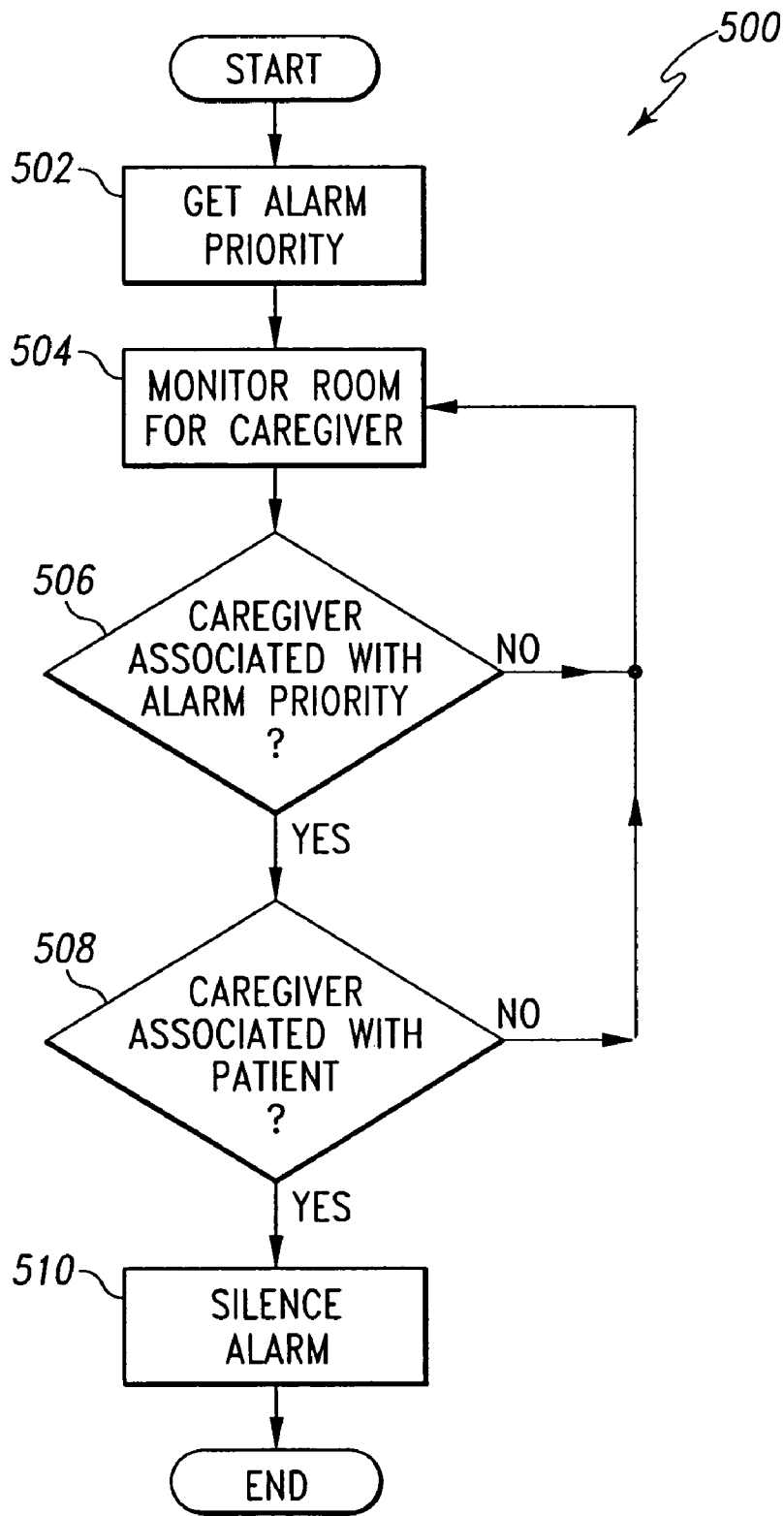

Fig. 5

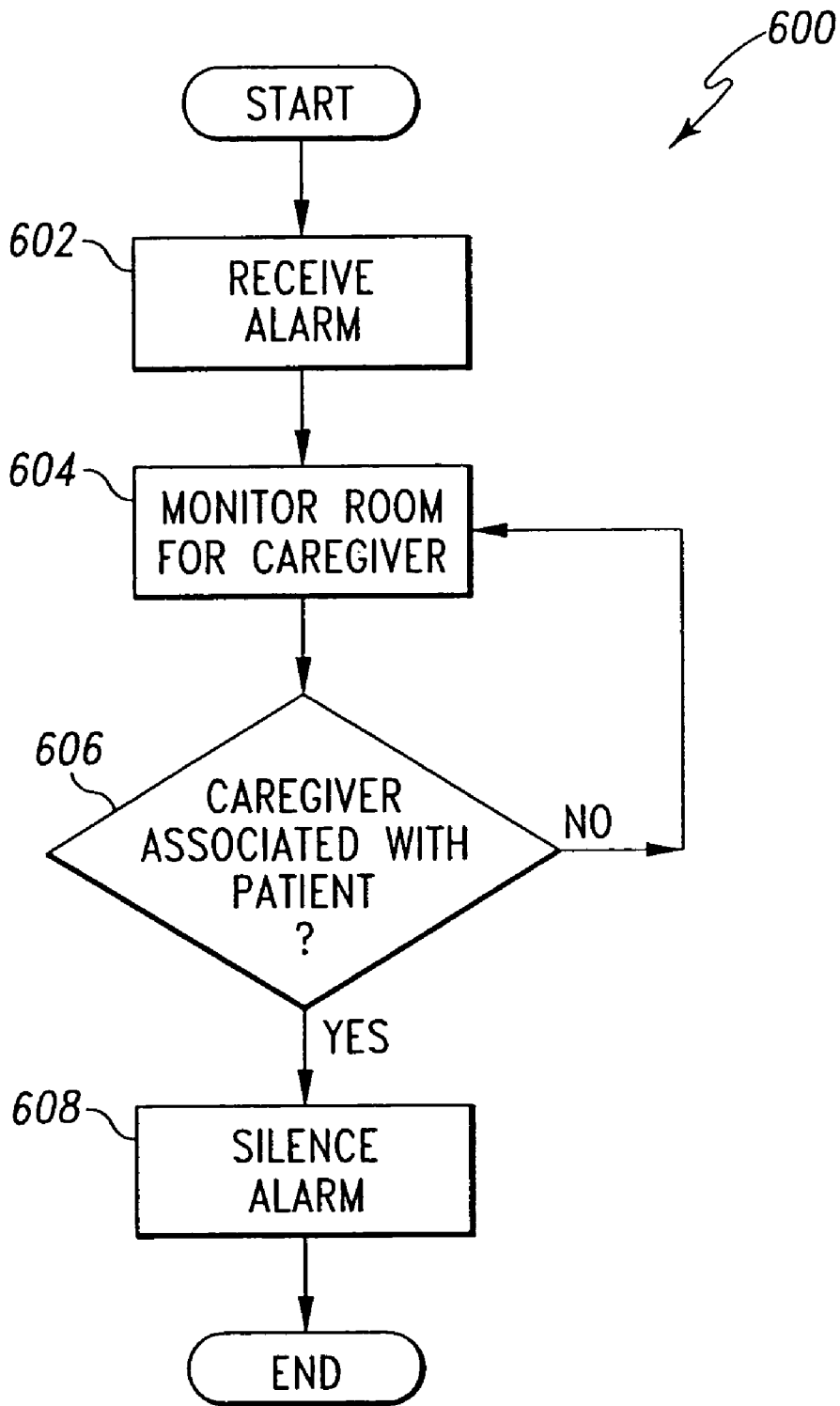

Fig. 6

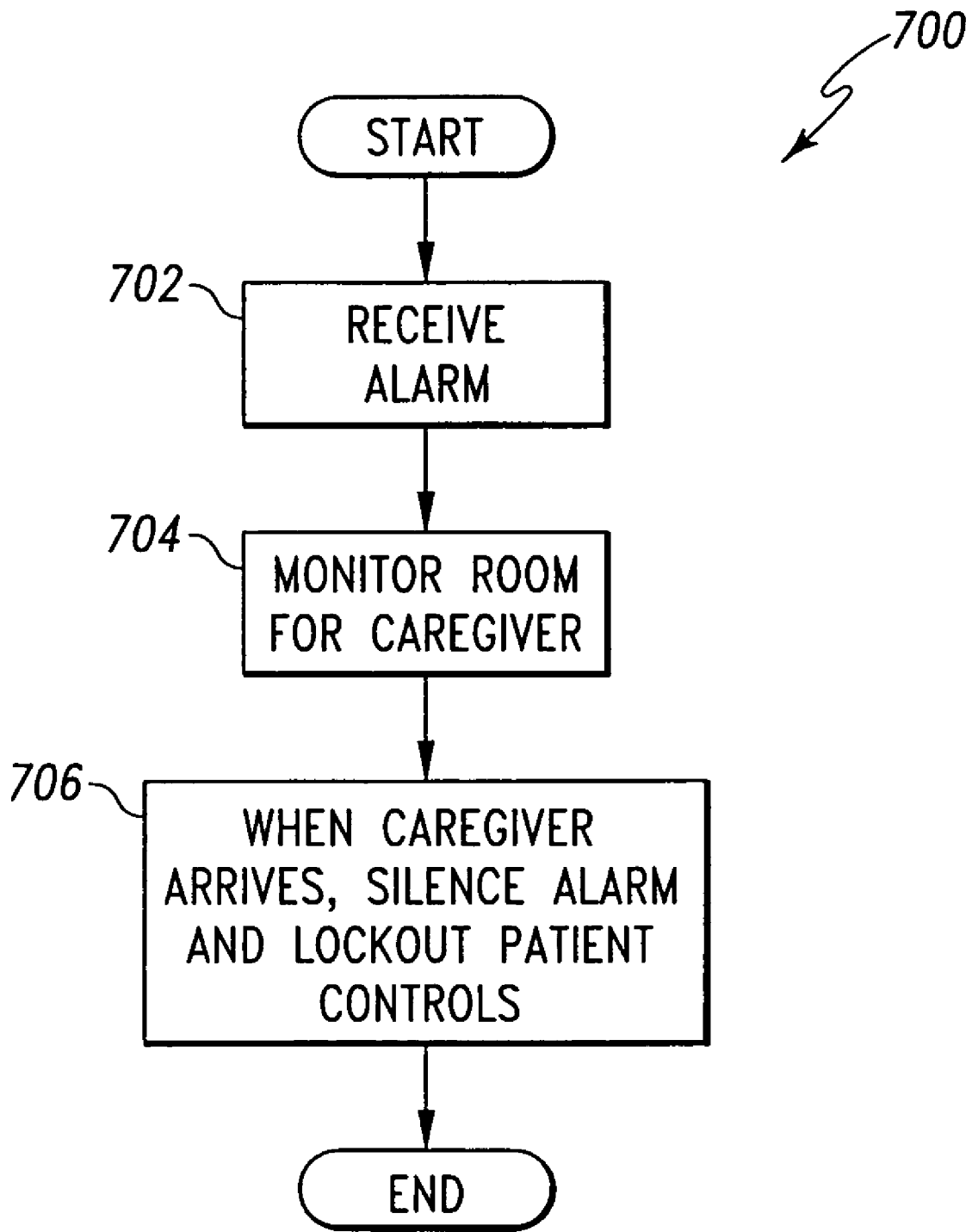

Fig. 7

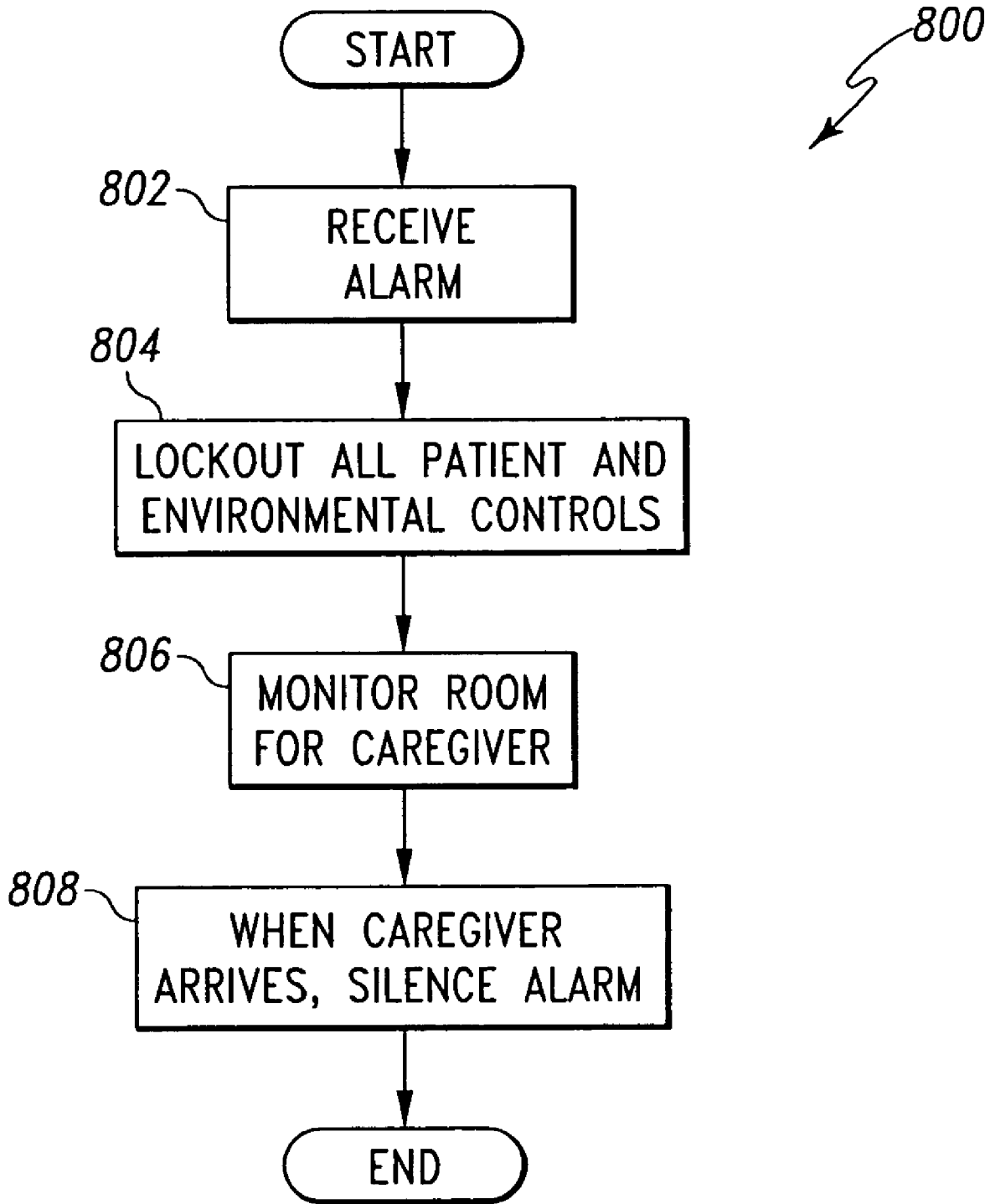

Fig. 8

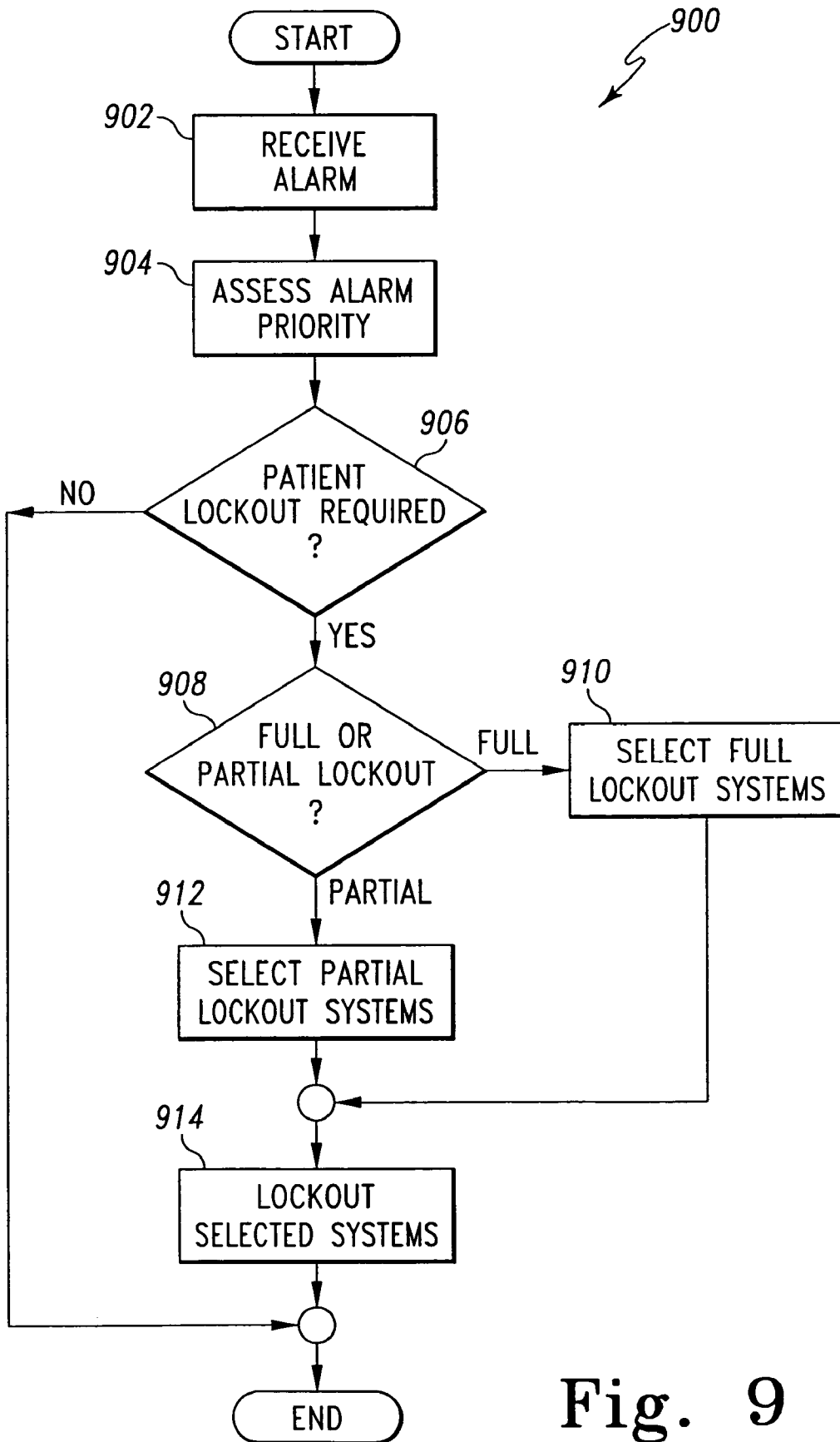

Fig. 9

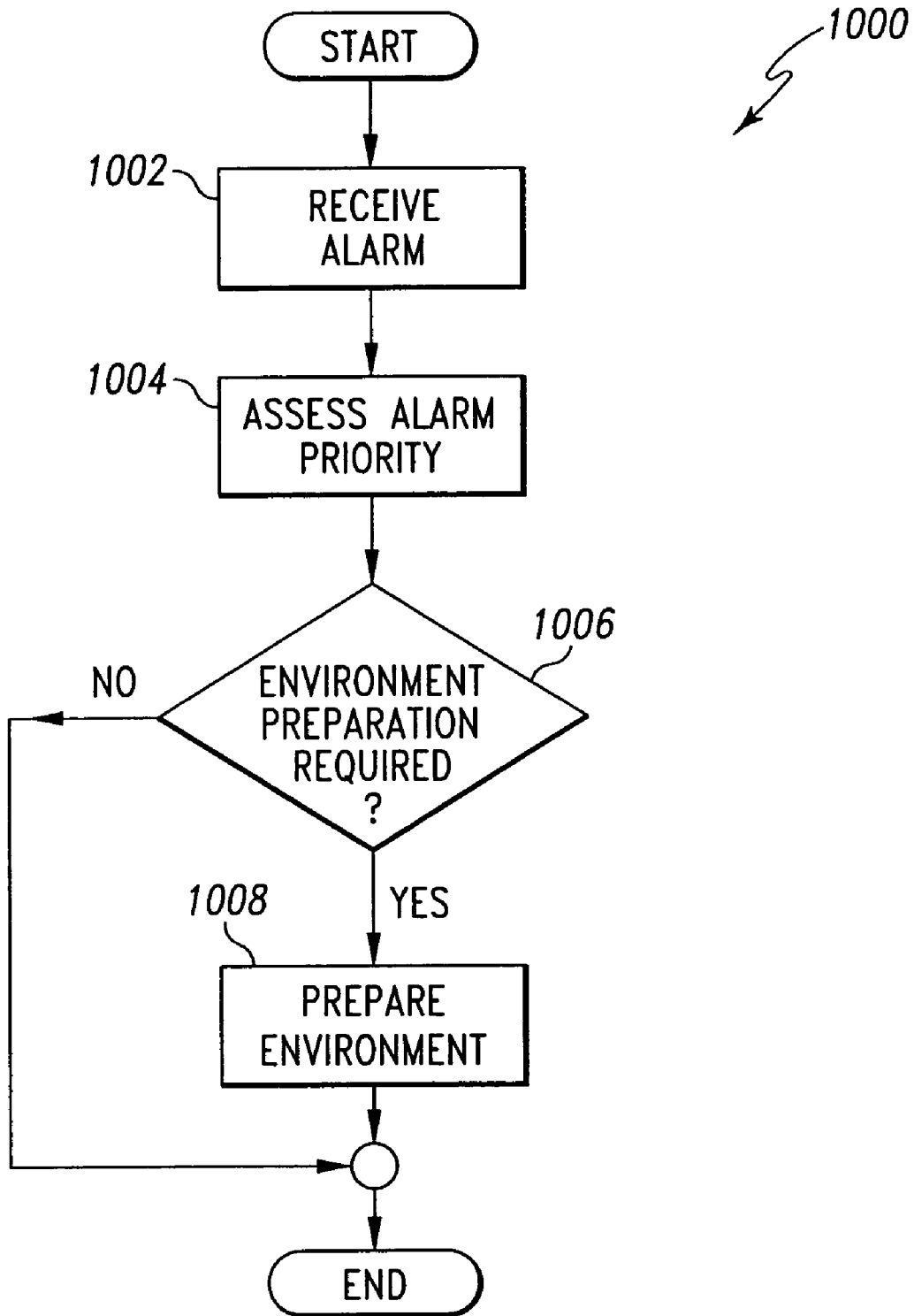

Fig. 10

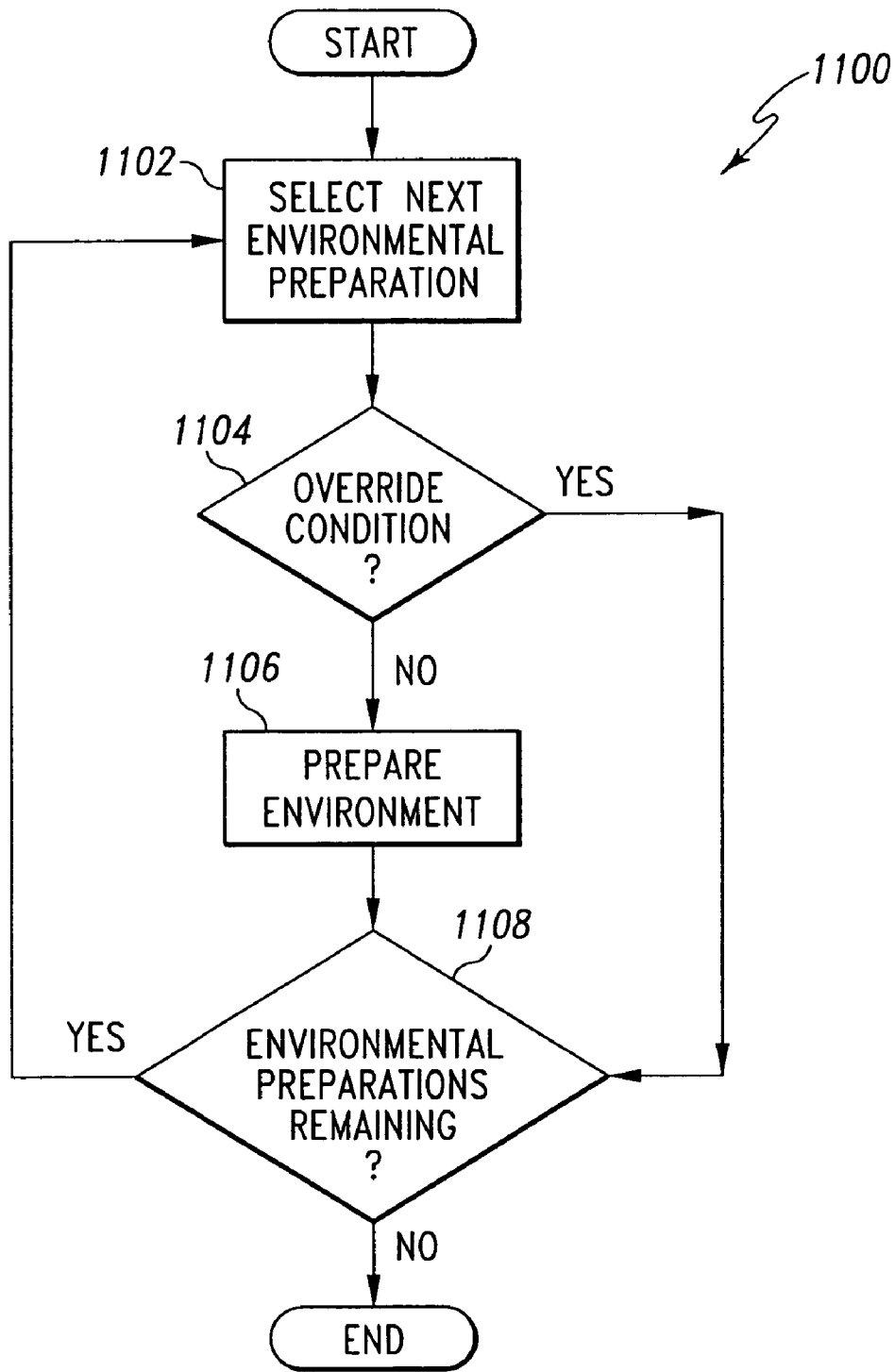

Fig. 11

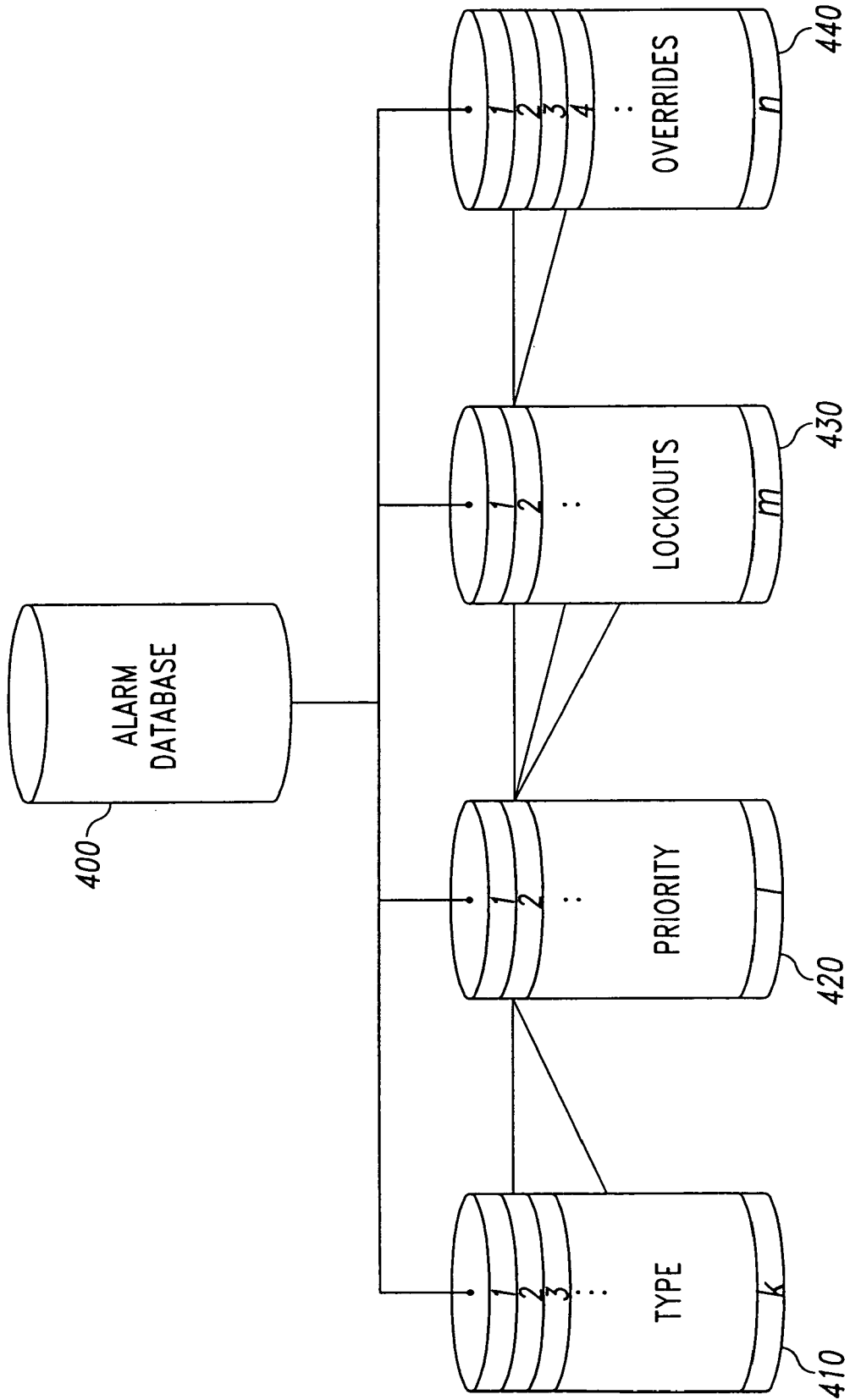

Fig. 12

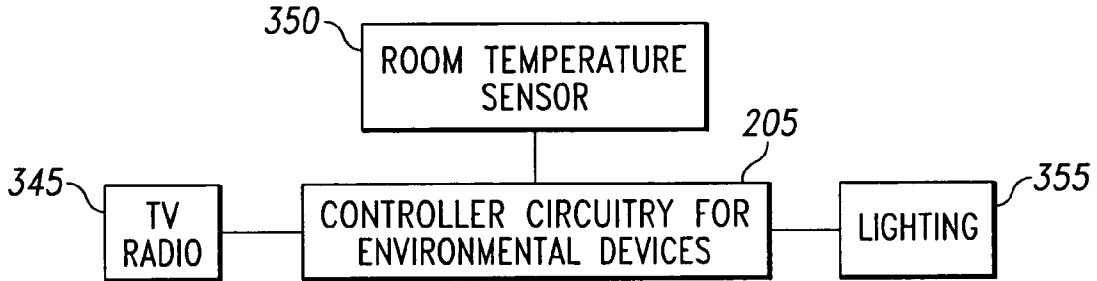

Fig. 13

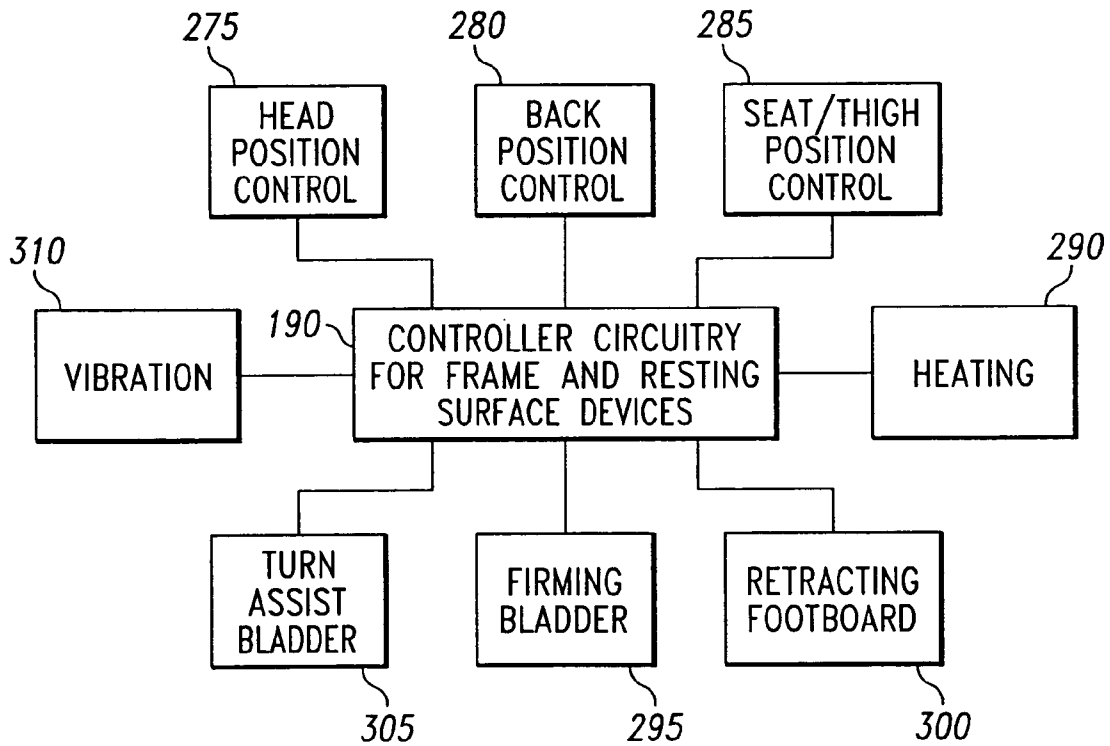

Fig. 14

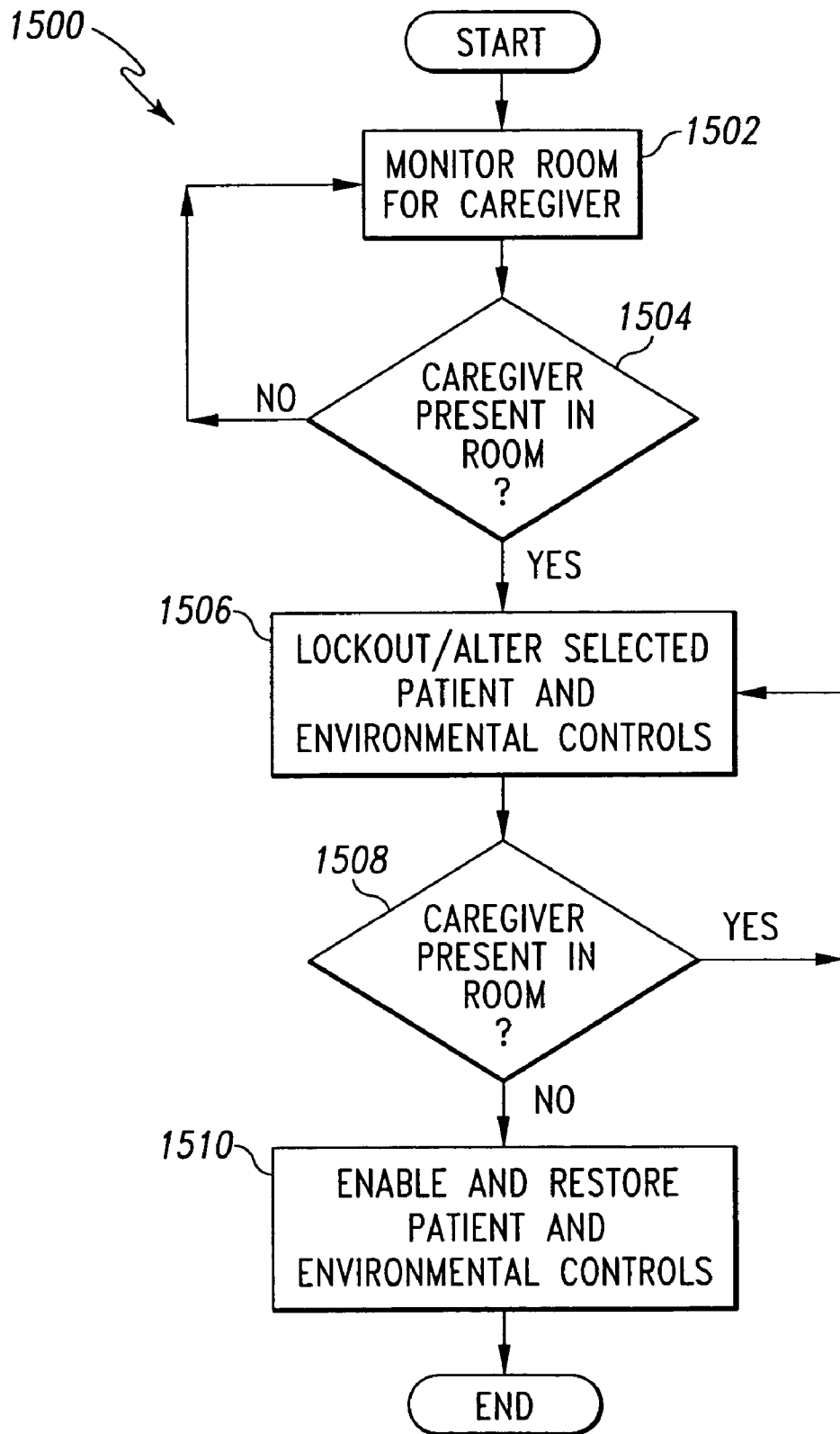

Fig. 15

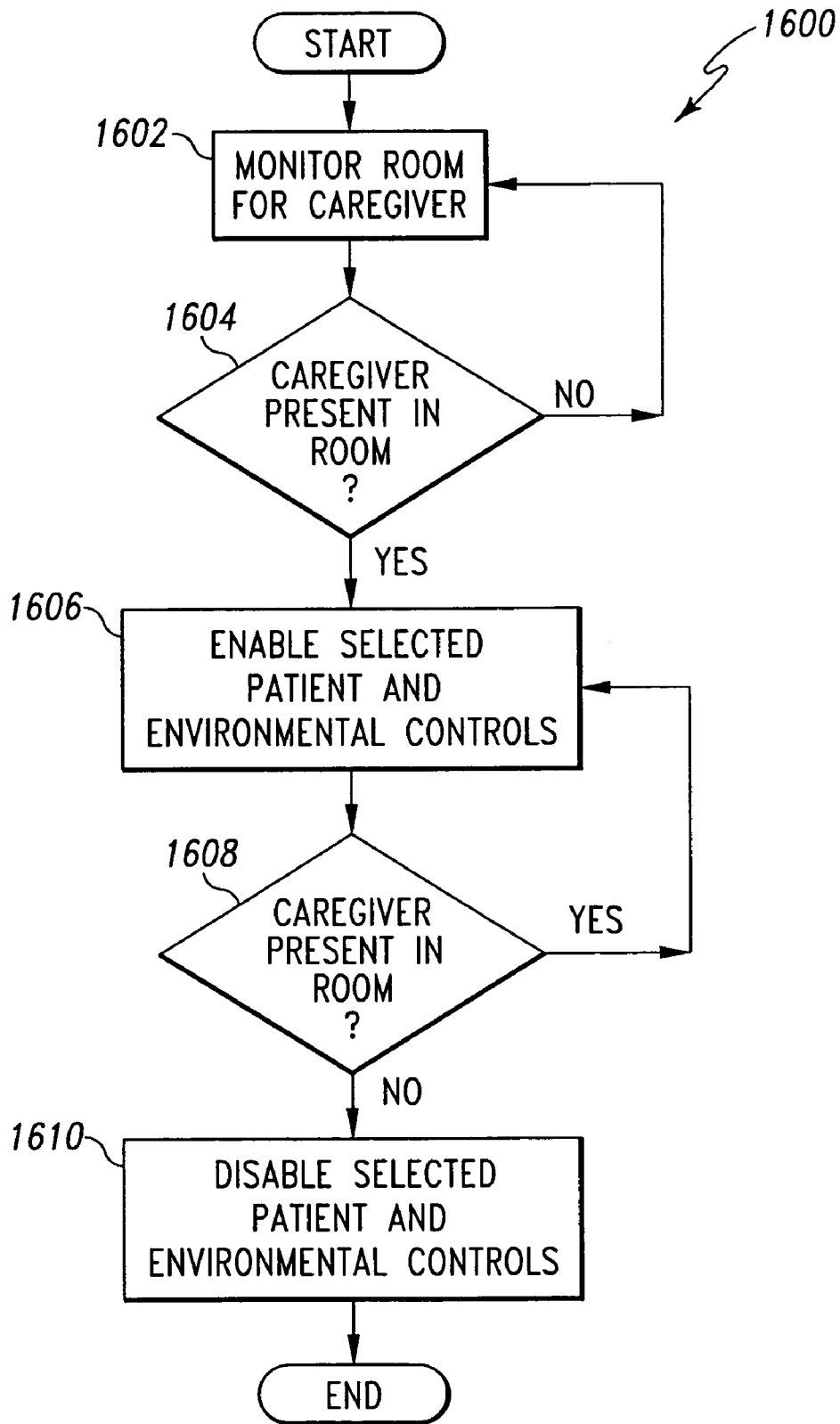

Fig. 16

CAREGIVER AND EQUIPMENT MONITORING AND CONTROL SYSTEM

REFERENCE TO PRIORITY APPLICATIONS

This application is a continuation of prior application Ser. No. 09/849,688, U.S. Pat. No. 6,876,303, filed May 4, 2001. This application also claims benefit of U.S. Provisional Application Ser. No. 60/202,283, entitled "Patient Point of Care Computer System", filed May 5, 2000; U.S. Provisional Application No. 60/202,284, entitled "Remote Control for a Hospital Bed", filed May 5, 2000; and U.S. Provisional Application No. 60/229,136, entitled "Patient Point of Care Computer System", filed Aug. 30, 2000.

CROSS REFERENCE TO CO-PENDING APPLICATIONS

The disclosures of co-pending U.S. Nonprovisional Application Ser. No. 09/849,580, entitled "Patient Point of Care Computer System", filed May 4, 2001, and U.S. Nonprovisional Application Ser. No. 09/848,941, entitled "Remote Control for a Hospital Bed" filed May 4, 2001 are incorporated herein by reference.

BACKGROUND AND SUMMARY OF THE INVENTION

The present invention relates to a hospital monitoring system, and more particularly, to hospital monitoring system for monitoring hospital personnel, a plurality of patient locations for patients, and associated devices.

Hospital staff, including doctors, nurses, physician assistants, orderlies, etc., provide patient care while the patient is undergoing treatment and/or therapy during a hospital visit. A number of systems have been developed to facilitate providing patient care, such as personnel locating systems, nurse call systems, bed status information systems, and patient monitoring devices. Details of such systems are disclosed in U.S. Pat. Nos. 6,067,019 (Bed Exit Detection Apparatus); U.S. Pat. No. 5,838,223 (Patient/Nurse Call System); U.S. Pat. No. 5,808,552 (Patient Detection System for a Patient-Support Device); U.S. Pat. No. 5,699,038 (Bed Status Information System for Hospital Beds); U.S. Pat. No. 5,561,412 (Patient/Nurse Call System); and U.S. Pat. No. 5,537,095 (Incontinence Detection Device), the disclosures of which are incorporated herein by reference. Additionally, co-pending U.S. Nonprovisional Applications Ser. Nos. 09/849,580, filed May 4, 2001, entitled "Patient Point of Care Computer System", and Ser. No. 09/848,941, filed May 4, 2001, entitled "Remote Control For a Hospital Bed", the disclosures of which are incorporated herein by reference, also disclose systems that have been developed to facilitate providing patient care.

The systems disclosed above facilitate various patient alarms, such as a patient exiting a bed, an incontinence event,

ment when an alarm is received. Further still, the disclosure is directed toward preparing the working environment when an alarm is received, subject to environmental and patient control overrides depending on the nature of the alarm and time of the alarm.

The system disclosed also provides for automatic lockouts of patient and environmental controls when the caregiver enters the room, regardless of the presence of an alarm. As a caregiver makes his or her rounds, the caregiver may need to tend to the patient's needs. Often a caregiver must ensure that patient activated controls are locked out during this time, as the patient may inadvertently activate a control and interfere with the caregiver's duties. Also disclosed is a system that provides for the automatic enablement of patient controls, bed controls, and/or environmental controls when a caregiver is in the room.

One illustrative embodiment prevents the status of bed lockouts from being changed without an authorized caregiver within the room. When the caregiver enters the room, the system receives a caregiver identification signal from a caregiver badge. After the system authenticates the identification signal, the system then permits the bed lockout status to be changed. The bed lockout controls prevent the patient on bed from actuating certain controls. These lockouts are typically actuated by pressing a button or a combination of two or more buttons on the bed to lock out various bed controls, environmental controls, or other functions.

Another embodiment is designed for use with beds which are movable from a generally flat bed position to a chair position. In this embodiment of the present invention, the bed is unable to move to a chair position unless an authorized caregiver is located within the room. Again, the system must receive and authenticate the identification signal from caregiver badge before the bed is permitted to move to the chair position.

In yet another embodiment, the status of patient environmental controls adjacent a bed is automatically altered when the caregiver enters the room. For example, in one embodiment the sound on a TV/radio device is muted and specific light sources are activated when the caregiver enters the room. A system receives the caregiver identification signal. After the system authenticates the identification signal, the system instructs the TV/radio device to mute all sound and the light source to activate specific lights. In another embodiment, the system locks out one or more of the environmental controls within the room once the control unit authenticates the identification signal from the caregiver badge. Therefore, the patient can no longer control the environmental functions such as, for example, the radio, television or lighting when an authorized caregiver is in the room.

According to the invention, a hospital monitoring system for monitoring hospital personnel, a plurality of patient locations for patients, and associated devices is disclosed. The system comprises a plurality of transmitters carried by hospital personnel, each transmitter periodically transmitting a transmitter signal unique to that transmitter; a plurality of receivers, each receiver corresponding to a patient location,

3

presence of hospital personnel in the patient location; and altering the state of the devices based the presence of hospital personnel.

Also according to the invention, a hospital monitoring system for monitoring hospital personnel, a plurality of patient locations for patients, and associated devices is provided. The system comprises a locating and tracking system configured to locate and track hospital personnel located in the plurality of patient locations; a computer coupled to the associated devices and the locating and tracking system, the computer configured to determine the presence of hospital personnel in the patient locations from the locating and tracking system, the computer further configured to alter device states based on the presence of hospital personnel. The computer also includes a database, the database comprising a patient database, the patient database associated each patient with a patient location; a hospital personnel database, the hospital personnel database associating each hospital personnel with a caregiver or non-caregiver class, the hospital personnel database further associating hospital personnel with a patient; and an alarm database, the alarm database associating a plurality of alarms with the hospital personnel.

Additional features of the invention will become apparent to those skilled in the art upon consideration of the following detailed description of illustrated embodiments exemplifying the best mode of carrying out the invention as presently perceived.

BRIEF DESCRIPTION OF THE DRAWINGS

The detailed description particularly refers to the accompanying figures in which:

FIG. 1 is a block diagram illustrating the components of the hospital monitoring and control system of the present invention;

FIG. 2 is a perspective view of a portion of a hospital room which illustrates a patient station in a patient room and the physical arrangement of other components, including an incontinence detection device;

FIG. 3 depicts a database structure used to associate patients with hospital personnel, and associate hospital personnel with alarms;

FIG. 4 depicts the database association for a specific patient record, the patient associated with hospital personnel, and the hospital personnel associated with alarms;

FIG. 5 is a flowchart of an illustrative embodiment of an automatic alarm silencing process that includes association of patients, hospital personnel and alarms;

FIG. 6 is a flowchart of another illustrative embodiment of an automatic alarm silencing process that includes association of patients and hospital personnel;

FIG. 7 is a flowchart of an illustrative embodiment of an alarm silencing process in conjunction with a patient control lockout that includes a lockout of patient activated controls;

FIG. 8 is a flowchart of another illustrative embodiment of an automatic alarm silencing process in conjunction with a patient control lockout that includes a lockout of patient activated controls upon the occurrence of the alarm;

4

the caregiver based on the alarm priority, with each environmental preparation subject to an override condition;

FIG. 12 depicts the database association of the alarm database, the database containing Type, Priority, Lockouts and Overrides fields;

FIG. 13 is a block diagram illustrating the control circuitry for several environmental controls;

FIG. 14 is a block diagram illustrating the bed controller and associated bed controls;

FIG. 15 is a flow chart of another illustrative embodiment describing a process which lockouts and/or alters selected patient and environmental controls when a caregiver is present in the room; and

FIG. 16 is a flow chart of another illustrative embodiment describing a process which enables selected patient and environmental controls when a caregiver is present the room.

DETAILED DESCRIPTION OF THE DRAWINGS

Referring now to the drawings, FIGS. 1 and 2 illustrates a block diagram of the hospital monitoring and control system 10 of the present invention, and an illustrative hospital environment in which the system is utilized.

FIG. 2 illustrates a patient room 130 which includes a patient station 22 and the physical arrangement of other components, including an incontinence detection device 65. The patient station 22 is illustratively a component of a nurse call system 40. Caregiver 110 wears a badge 24 which clips to the caregiver's 110 clothing. The badge 24 transmits a pulse-coded signal, preferably infrared or RF, which is received by receiver 25, which is preferably located at the patient station 22, and/or an overhead receiver 125 so that the location and tracking systems 20 can determine and continuously update locations of caregivers 110 on duty. Overhead light 122 provides room illumination, and reading light 123 provides reading illumination for the patient. Overhead light 122 and reading light 123 are controlled by light controls 132 and 133, respectively.

Pillow unit 28 connects via a cable 26 to a receptacle 27 which, in turn, is connected to the nurse call system 40. Pillow unit 28 allows the patient 100 to manually place a nurse call or alarm via nurse call system 40. Pillow unit also allows patient 100 access to bed 90 controls and environmental controls 50. Bed 90 controls are also accessible by the caregiver 110 via control panel 140.

Incontinence detection device 65 is interposed between the bed 90 and patient 110. Incontinence detection device 65 is connected to the computer 12 via bed 90 electronics and cable 91 via receptacle 27.

The system 10 illustratively includes a computer 12 configured to monitor various system alarms, device status, the hospital personnel information, and patient information. Computer 12 is coupled to a location and tracking system 20. Location and tracking system 20 monitors and tracks the location of hospital personnel, patients and equipment within the hospital. Computer 12 is also connected to nurse call system 40. Nurse call system 40 is associated with various alarms 42. The alarms 42 illustratively include the following:

-continued

ALARM	PRIORITY	GENERATED BY
Shower	4	Human/Input Device
Patient Equipment	5	Automatic/Input Device

Illustratively, the alarms **42** will place a call to a caregiver through location and tracking system **20** and nurse call system **40**.

Computer **12** is also connected to hospital bed **90**. Hospital bed **90** is associated with alarms **92**. Alarms **92** include bed malfunction alarms and/or bed exit alarms, and incontinence detection device **65** alarms. Illustratively, alarms **92** will place a call to a caregiver through location and tracking system **20** and nurse call system **40**.

Bed **90** includes frame and resting surface devices **190** adjust the position of bed **90** and the position and shape of the resting surface, as illustrated in FIG. **14**. In addition, other devices are included in frame and resting surface devices **190**, such as resting surface vibration, temperature and firmness controls. Caregiver **110** accesses and changes the state of frame and resting surface devices **190** via control panel **140**, shown in FIG. **2**. FIG. **14** shows several frame and resting surface devices **190**, however FIG. **14** should not be considered an exhaustive list. Examples of frame and resting surface devices **190** include head position control **275**, back position control **280**, seat/thigh position control **285**, heating control **290**, firming bladder **295**, retracting footboard control **300**, turn assist bladder control **305** and vibration control **310**.

Head position control **275**, back position control **280** and seat/thigh position control **285** all alter the shape of the resting surface of bed **90**. Head position control **275** raises or lowers the head position of the resting surface generally coincident with the head of the patient. Back position control **280** raises or lowers the middle portion of the resting surface generally coincident with the back of the patient. Seat/thigh position control **285** raises or lowers the lower portion of the resting surface generally coincident with the seat and thighs of a patient.

Heating control **290** controls the temperature of the resting surface of bed **90**. Similarly, vibration control **310** controls the vibratory action of the resting surface of bed **90**. Firming bladder control **295** controls the firmness of the resting surface of bed **90**. Retracting footboard control **300** adjusts the length of the foot portion of the resting surface of bed **90**. This allows bed **90** to accommodate patients of various heights comfortably. Turn assist bladder control **305** controls rotation of the patient to reduce the likelihood of pulmonary complications. An interface pressure sensor and controller for a patient support surface such as an air mattress may also be coupled to the controller **190**.

Computer **12** is also connected to coupler **60**. The computer **12** may be coupled to monitors **26**, treatment devices **72**, and therapy devices **82** through coupler **60**. Illustratively, coupler **60** may be an RS-232 compatible cable or other suitable connector, such as a RS-485 compatible cable, Ethernet, or other network connection device known to those of ordinary skill in the art. Computer **12** processes signals from the monitors **62**, treatment devices **72**, and therapy devices **82** on a real time basis. The monitors **62**, treatment devices **72**, and therapy devices **82** include, but are not limited to, heart rate monitors, temperature sensors, blood pressure monitors (invasive and noninvasive), EKG monitors, blood oxygen sensors, capnographs, ventilators, IV pumps, scales, chest drainage monitors, and the like. Monitors **62**, treatment

devices **72** and therapy devices **82** have associated alarms **64**, **74** and **84**, respectively. Illustratively, alarms **64**, **74**, and **84** will place a call to a caregiver through location and tracking system **20** and nurse call system **40**.

Computer **12** is also connected to environmental devices **50**. Alarm **52** is associated with environmental devices **50**. Environmental devices **50** illustratively include temperature control devices, such as a thermostat, and humidity control devices, such as a humidifier. Additionally, environmental devices **50** illustratively include entertainment devices such as a television/radio **120**, and lighting such as overhead light **122** and reading light **123**, all of which do not have alarms associated therewith.

Environmental devices **50** control environmental parameters within the patient room. FIG. **13** shows several different environmental devices **50**; however FIG. **13** should not be considered an exhaustive list. Examples of environmental devices **50** include TV/radio **120** control **345**, room temperature control **350** and lighting control **355**, which control overhead light **122** and reading light **123**.

TV/radio **120** control **345** controls the functions of the TV/radio **120** in the room. Room temperature control **350** is a thermostat control for altering the temperature of the patient's room. Lighting control **355** controls overhead light **122** and reading light **123**, and their brightness level.

In one embodiment, the status of the environmental controls is automatically altered when caregiver **110** enters the room. For example, the sound on TV/radio **120** is muted and overhead light **122** and/or reading light **123** controlled by lighting control **355** are activated. When caregiver **110** enters the room, receiver **25** receives the caregiver identification signal broadcast by caregiver badge **24**. After the computer **12** authenticates the identification signal, the computer **12** instructs TV/radio **120** control **345** to mute all sound and lighting device **355** to illuminate overhead light **122** and reading light **123**.

In another embodiment of the present invention, the computer **12** overrides one or more of the environmental controls within the room once the computer **12** authenticates the identification signal from the badge **24**. In other words, the patient can no longer control the environmental functions such as, for example, the radio, television or lighting when an authorized caregiver **110** is in the room.

Bed **90** includes lockout controls which prevent the patient **100** on bed **90** from actuating certain controls. These lockouts are typically actuated by pressing a button or a combination of two or more buttons on the bed to lock out various bed controls, environmental controls, or other functions. In one embodiment of the present invention, these bed lockouts cannot be changed without an authorized caregiver **110** within the room. In other words, when caregiver **110** enters the room, the receiver **25** receives the caregiver identification signal from the badge **24**. After the control unit authenticates the identification signal **24**, computer **12** then permits the bed lockout status to be changed.

Certain beds such as the TotalCare® bed available from Hill-Rom, Inc. are capable of moving from a generally flat bed position to a chair position. In one embodiment of the present invention, the bed is unable to move to a chair position unless an authorized caregiver **110** is located within the room. Again, the computer **12** must receive and authenticate the identification signal from badge **24** before the bed is permitted to move to the chair position. Thus, a feature is selectively locked out in the absence of a caregiver **110**.

FIG. **15** shows a flow chart **1500** of the illustrative embodiments, and describes a process which lockouts and/or alters selected patient and environmental controls when a caregiver

110 is present in the room. In step 1502, the locating and tracking system 20 monitors the room for a caregiver 110. If a caregiver enters the room, step 1504 exits the monitoring loop and enables step 1506, which locks out and/or alters selected patient and environmental controls. In step 1508, the locating and tracking system 20 monitors the room for the presence of the caregiver 110 and retains the state of 1506 as long as the caregiver 110 is in the room. When the caregiver 110 exits the room, the patient lockouts are removed and the environment is restored, along with the patient 100 controls to alter the environment.

FIG. 16 shows a flow chart 1600 of another one of the illustrative embodiments, and describes a process which enables and/or alters selected patient and environmental controls when a caregiver 110 enters the room. In step 1602, the locating and tracking system 20 monitors the room for a caregiver 110. If a caregiver enters the room, step 1604 exits the monitoring loop and enables step 1606, which enables and/or alters selected patient and environmental controls. In step 1608, the locating and tracking system 20 monitors the room for the presence of the caregiver 110 and retains the state of 1606 as long as the caregiver 110 is in the room. When the caregiver 110 exits the room, the patient and environmental lockouts are restored.

FIG. 3 depicts a database structure used to associate patients with hospital personnel, and associate hospital personnel with alarms. Patient information is stored in patient database 200. As depicted in FIG. 3, there are numerous patients in the database, ranging from record number 1 to k.

Hospital personnel information is stored in hospital personnel database 300. There are numerous hospital personnel in the hospital personnel database 300, ranging from record number 1 to m. Furthermore, hospital personnel information stored in hospital personnel database 300 is categorized by personnel position. Illustratively, the hospital personnel database contains a "doctor" class, a "nurse" class, an "orderly" class, and a "non-caregiver" class. Non-caregiver class illustratively includes security staff, administrative staff, or janitorial staff.

Alarm database 400 stores alarm information for alarm records 1 to n, each record associated with a different alarm. Furthermore, alarm information stored in alarm database 300 includes alarm type and alarm priority. Thus, alarm record 1, for example, may be associated with a cardiac arrest and allocated priority 1, the highest priority and thus requiring immediate attention, and alarm record n may be associated with an incontinence event, and be allocated a lower priority.

FIG. 4 depicts the database association for a specific patient record, the patient associated with hospital personnel, and the hospital personnel associated with alarms. Illustratively, patient record 221 is associated with hospital personnel records 11, 131, and 211. In the present example, the patient represented by patient record 221 has been admitted for a heart procedure requiring surgery. Hospital personnel records 11, 131, and 211 correspond to a surgeon, a cardiologist and a nurse, respectively. Alarms records 1-11 in alarm database 400 are associated with hospital personnel records 11, 131, and 211. In the illustrative example, alarm records 1-3 are associated with hospital personnel record 11, alarm records 3-7 are associated with hospital personnel record 131, and alarm records 8-11 are associated with hospital personnel record 211. Illustratively, alarm record 1 corresponds to a cardiac arrest, and has the highest priority, which requires the attention of a cardiologist. Alarm record 3 corresponds to a less severe cardiac event, such as an irregular heart rate, and thus has a lesser priority, and requires either the cardiologist or surgeon.

The flow diagram 500 of FIG. 5 depicts one illustrative embodiment of the automatic alarm silencing process that includes association of patients, hospital personnel and alarms. In step 502, the computer 12 receives an alarm from either the location and tracking system 20, the nurse call system 40, a treatment device 72, a therapy device 82, environmental devices 50, or the hospital bed 90. Upon receiving the alarm signal, computer 12 gets the alarm priority from alarm database 400, and may also notify the caregiver at their current location. In step 504, the computer monitors the room 130 from which the alarm was received for a caregiver. In the illustrative embodiment disclosed herein, patient station 22 monitors the room 130 via receiver 25. Upon entering the room 130, a caregiver is identified by badge 24, which emits an infrared pulse and is detected by receiver 25. Computer 12 receives the caregiver identification and thus identifies the associated hospital personnel record in hospital personnel database 300.

In step 506, computer 12 determines whether the caregiver in room 130 is associated with the alarm priority stored in alarm database 400. For example, if the alarm priority is 3, indicating a cardiac event of lower priority than a cardiac arrest, and the person entering the room is identified as a non-caregiver, e.g., a security officer, the alarm will not be silenced. Similarly, if the caregiver is identified as a nurse, the alarm will not be silenced. Conversely, if the caregiver is identified as a cardiologist or surgeon, which in this example is associated with the alarm of priority 3, then step 508 determines if the doctor identified is associated with that patient. If the doctor is associated with the patient, then the alarm is silenced in step 510. If the doctor is not associated with the patient, the alarm is not silenced.

The flow diagram 600 of FIG. 6 depicts another illustrative embodiment of the automatic alarm silencing process that includes associating patients with hospital personnel. In step 602, the computer 12 receives an alarm from either the location and tracking system 20, the nurse call system 40, a treatment device 72, a therapy device 82, environmental devices 50, or the hospital bed 90. Upon receiving the alarm signal, computer 12 monitors the room 130 from which the alarm was received for a caregiver, as shown in step 604. In the illustrative embodiment disclosed herein, patient station 22 monitors the room 130 via receiver 25. Upon entering the room 130, a caregiver is identified by badge 24, which emits an infrared and/or RF pulse and is detected by receiver 25. Computer 12 receives the caregiver identification and thus identifies the associated hospital personnel record in hospital personnel database 300. Step 606 determines if the caregiver is associated with the patient. If the caregiver is associated with the patient, then the alarm is silenced in step 608. If the caregiver is not associated with the patient, the alarm is not silenced.

The flow diagram 700 of FIG. 7 depicts another illustrative embodiment of the automatic alarm silencing process that includes a lockout of patient activated controls. In step 702, the computer 12 receives an alarm from either the location and tracking system 20, the nurse call system 40, a treatment device 72, a therapy device 82, environmental devices 50, or the hospital bed 90. Upon receiving the alarm signal, computer 12 monitors the room 130 from which the alarm was received for a caregiver, as shown in step 704. In the illustrative embodiment disclosed herein, patient station 22 monitors the room 130 via receiver 25. Upon entering the room 130, a caregiver is identified by badge 24, which emits an infrared pulse and is detected by receiver 25. Once the caregiver enters the room, step 706 silences the alarm and locks out any patient activated controls, such as bed 90 controls or television/radio

120 approach that decreases the likelihood that the patient will be immediately shut off. As a cardiac event

100 may inadvertently interfere with caregiver 110 while the caregiver 110 administers the required therapy in response to the alarm.

The flow diagram 800 of FIG. 8 depicts another illustrative embodiment of the automatic alarm silencing process in conjunction with a patient control lockout that includes a lockout of patient activated controls immediately upon the occurrence of an alarm. Locking out patient and environmental controls as soon as an alarm is received is desirable should the patient 100 be suffering from severe condition, such as a cardiac arrest or seizure, so as to prevent a patient's involuntary movement from accidentally activating a bed 90 or environmental devices 50.

In step 802, the computer 12 receives an alarm from either the location and tracking system 20, the nurse call system 40, a treatment device 72, a therapy device 82, environmental devices 50, or the hospital bed 90. Upon receiving the alarm signal, computer 12 immediately locks out all patient and environmental controls as shown in step 804. Controller 12 then monitors the room 130 from which the alarm was received for a caregiver, as shown in step 806. Once the caregiver enters the room, step 808 silences the alarm.

Often an alarm may sound when a caregiver 110 is present in the hospital room 130. In such a situation, it is not desirable to automatically cancel the alarm, as the caregiver 110 may not immediately notice the alarm, or the alarm may be suppressed before it emits an audible signal. Accordingly, alternative embodiments to FIGS. 5-8 include a step that determines whether a caregiver 110 is present in the room 130 when the alarm sounds; if a caregiver 110 is present, the alarm is not automatically suppressed by the presence of the caregiver 110. Computer 12 is configured to allow the alarm to sound for a predetermined amount of time so that the caregiver 110 can assess which alarm is sounding. Alternatively, computer 12 is configured to require the caregiver 110 to manually shut off the alarm. Conversely, if a caregiver 110 is not in the room 130, then the processes are the same as depicted in FIGS. 5-8.

Depending on the alarm priority, locking out patient controls may not be desirable. For example, if patient 100 experiences an incontinence event, the patient may desire to exit the bed to personally tend to his hygiene needs. However, locking out the bed controls can impede patient 100 from

usually warrants a response team, shutting off the television/radio 120 will ensure that this device will not distract any member of the response team. Conversely, if a patient 100 experiences only a slight incontinence event while watching television, which may not even be noticeable to the patient 100, the better therapy may be to let the patient 100 rest and tend to the patient 100 at a later time. As such, the television/radio 120 will not be shut off automatically. Thus, the environmental devices 50 may not be altered, based on the event magnitude of an associated alarm.

FIG. 10 shows a flow chart 1000 of another illustrative embodiment describing that process that prepares the patient environment for the caregiver based on the alarm priority. In step 1002, computer 12 receives an alarm. In step 1004, the alarm priority is assessed. Step 1006 determines whether environmental preparation is required. A higher priority alarm, such as a code blue or cardiac arrest alarm, will warrant environmental preparation. Conversely, a lower priority alarm, such as a slight incontinence event, will not require an environmental preparation. If an environmental preparation is required, the environment is prepared in step 1008.

FIG. 11 shows a flow chart 1100 of another illustrative embodiment describing a process that prepares the patient environment for the caregiver based on the alarm priority, with each environmental preparation subject to an override condition. Illustratively, an environmental preparation can be subject to an override condition depending on the time of day. For example, if patient 100 experiences a cardiac arrest in the evening while sleeping, it is likely that room 130 lighting is low or off. Given the severity of a cardiac arrest, which warrants a response team, an environmental preparation includes turning on the room 130 lighting. As such, overhead light 122 will immediately illuminate the room, as a response team will most likely arrive soon after the alarm is generated. Conversely, if a patient 100 experiences only a slight incontinence event during the evening while sleeping, the better therapy may be to let the patient 100 rest and tend to the patient 100 in the morning. As such, no environmental preparations are required and overhead light 122 remains off.

Once the environmental preparations are determined, step 1102 selects the next environmental preparation from the list, beginning with the first. In step 1104, the environmental preparation is checked for an override condition. Illustratively, overhead light 122, which normally would illuminate

11

of the patient **100** or possibly a life threatening condition the patient **100** is experiencing. As shown in FIG. **12**, two records from the type **410** field have been assigned a priority **2**. Thus, if an alarm corresponding to either of those two records is received, it is assigned priority **2**.

The lockouts **430** field stores the patient lockouts, the environmental lockouts, and environmental preparations. Illustratively, the lockouts correspond to the alarm priority. As shown

12

7. The system of claim **1**, wherein the associated device has an alarm; and the computer is configured to detect the alarm, and lock out at least one of the plurality of patient controls upon detecting an alarm.

5 8. The system of claim **1**, wherein the associated device has an alarm; and the computer is configured to detect the alarm, and lock out at least one of the plurality of patient controls

13

altering the state of the patient control based on the presence of the caregiver in the monitored location.

24. The method of claim 23, further comprising the step of silencing an alarm associated with the device when the caregiver is present in the monitored location.

25. The method of claim 23, further comprising the step of detecting an alarm associated with the device; determining whether the caregiver is present in the monitored location when the alarm is initially detected; silencing the alarm after a predetermined amount of time if the caregiver is present in the monitored location when the alarm is initially detected; and silencing the alarm when the caregiver is initially detected in the monitored location if the caregiver is not present in the monitored location when the alarm is initially detected.

26. The method of claim 23, further comprising the steps of:
 associating the caregiver with a patient; and
 associating the caregiver with an alarm associated with the device.

27. The method of claim 26, further comprising the step of silencing the alarm when the caregiver associated with the patient and associated with the alarm is present in the monitored location.

28. The method of claim 23, wherein the step of altering the state of the patient control of the device based the presence of the caregiver includes the step of
 detecting an alarm associated with the device; and
 preventing patient control of the device when an alarm is detected.

29. The method of claim 23, wherein the step of altering the state of the patient control of the device based the presence of the caregiver includes the step of
 preventing patient control of the device when the caregiver is present in the monitored location.

30. The method of claim 23, wherein the step of altering the state of the patient control of the device based the presence of the caregiver includes the step of
 enabling patient control of the device when the caregiver is present in the monitored location.

31. A method of controlling a device having a patient control that is located in a monitored location, the method comprising:

associating the device to the monitored location;
 determining the presence of a caregiver in the monitored location; and
 altering the state of the patient control based on the presence of the caregiver in the monitored location.

32. The method of claim 31, further comprising the step of silencing an alarm associated with the device when the caregiver is present in the monitored location.

33. The method of claim 31, further comprising the step of detecting an alarm associated with the device; determining whether the caregiver is present in the monitored location when the alarm is initially detected; silencing the alarm after a predetermined amount of time if the caregiver is present in the monitored location when the alarm is initially detected; and silencing the alarm when the caregiver is initially detected in the monitored location if the caregiver is not present in the monitored location when the alarm is initially detected.

14

34. The method of claim 31, further comprising the steps of:

associating the caregiver with a patient; and
 associating the caregiver with an alarm associated with the device.

35. The method of claim 34, further comprising the step of silencing the alarm when the caregiver associated with the patient and associated with the alarm is present in the monitored location.

36. The method of claim 31, wherein the step of altering the state of the patient control of the device based the presence of the caregiver includes the step of

detecting an alarm associated with the device; and
 preventing patient control of the device when an alarm is detected.

37. The method of claim 31, wherein the step of altering the state of the patient control of the device based the presence of the caregiver includes the step of
 preventing patient control of the device when the caregiver is present in the monitored location.

38. The method of claim 31, wherein the step of altering the state of the patient control of the device based the presence of the caregiver includes the step of
 enabling patient control of the device when the caregiver is present in the monitored location.

39. A method of controlling devices in a monitored location, the method comprising:

associating alarm conditions with the devices;
 monitoring the monitored location for a triggering alarm condition;
 associating the devices with the monitored location;
 altering the state of the devices based on the triggering alarm condition;
 associating an alarm priority with the triggering alarm condition; and
 preventing patient control of selective devices based on the alarm priority.

40. A method of controlling devices in a monitored location, the method comprising:

associating alarm conditions with the devices;
 monitoring the monitored location for a triggering alarm condition;
 associating the devices with the monitored location;
 altering the state of the devices based on the triggering alarm condition;
 associating an alarm priority with the triggering alarm condition; and
 altering the state of the devices based on the alarm priority.

41. A method of controlling devices in a monitored location, the method comprising:

associating alarm conditions with the devices;
 monitoring the monitored location for a triggering alarm condition;
 associating the devices with the monitored location;
 altering the state of the devices based on the triggering alarm condition;
 associating an override condition to the triggering alarm condition; and
 not altering the state of the devices when the triggering alarm condition is detected if the override condition exists.

* * * * *